



US010029283B2

(12) **United States Patent**
Deshpande et al.

(10) **Patent No.:** **US 10,029,283 B2**

(45) **Date of Patent:** **Jul. 24, 2018**

(54) **METHOD AND APPARATUS FOR SORTING PARTICLES**

(71) Applicant: **CYTONOME/ST, LLC**, Boston, MA (US)

(72) Inventors: **Manish Deshpande**, Canton, MA (US);
John R. Gilbert, Brookline, MA (US)

(73) Assignee: **CYTONOME/ST, LLC**, Bedford, MA (US)

(*) Notice: Subject to any disclaimer, the term of this patent is extended or adjusted under 35 U.S.C. 154(b) by 7 days.

(21) Appl. No.: **14/828,252**

(22) Filed: **Aug. 17, 2015**

(65) **Prior Publication Data**

US 2015/0352597 A1 Dec. 10, 2015

Related U.S. Application Data

(60) Continuation of application No. 14/281,303, filed on May 19, 2014, now Pat. No. 9,550,215, which is a (Continued)

(51) **Int. Cl.**
B07C 5/36 (2006.01)
G01N 15/10 (2006.01)
(Continued)

(52) **U.S. Cl.**
CPC **B07C 5/36** (2013.01); **B01L 3/50273** (2013.01); **B01L 3/502715** (2013.01);
(Continued)

(58) **Field of Classification Search**
CPC ... **B07C 5/342**; **B07C 5/3425**; **F16K 99/0046**;
F16K 99/0048; **F16K 99/0061**;
(Continued)

(56) **References Cited**

U.S. PATENT DOCUMENTS

2,015,522 A * 9/1935 Hoffman B03B 5/32
209/205
2,646,882 A * 7/1953 Frost, Jr. B03D 1/06
209/170

(Continued)

FOREIGN PATENT DOCUMENTS

EP A 0 177 718 4/1986
EP A 0 745 682 12/1996

(Continued)

OTHER PUBLICATIONS

A Survey of Ferromagnetic Liquid Applications, M.P. Perry, p. 219-230, Thermomechanics of Magnetic Fluids, Theory and Applications, Edited by B. Berkovsky, Science Sector, UNESCO, Proceedings of the International Advanced Course and Workshop on Thermomechanics of Magnetic Fluids Organized by the International Centre for Mechanical Sciences, cited reference to "Magnetic Fluids: Magnetic Forces and Pumping Mechanisms", C.W. Miller, Sibley School of Mechanical and Aerospace Engineering, Cornell University, Ithaca, New York, Final Technical Report, Sep. 1973.

(Continued)

Primary Examiner — Joseph C Rodriguez

(74) *Attorney, Agent, or Firm* — McCarter & English, LLP; David R. Burns

(57) **ABSTRACT**

A method and apparatus for sorting particles moving through a closed channel system of capillary size comprises a bubble valve for selectively generating a pressure pulse to separate a particle having a predetermined characteristic from a stream of particles. The particle sorting system may further include a buffer for absorbing the pressure pulse. The particle sorting system may include a plurality of closely coupled sorting modules which are combined to further increase the sorting rate. The particle sorting system may

(Continued)

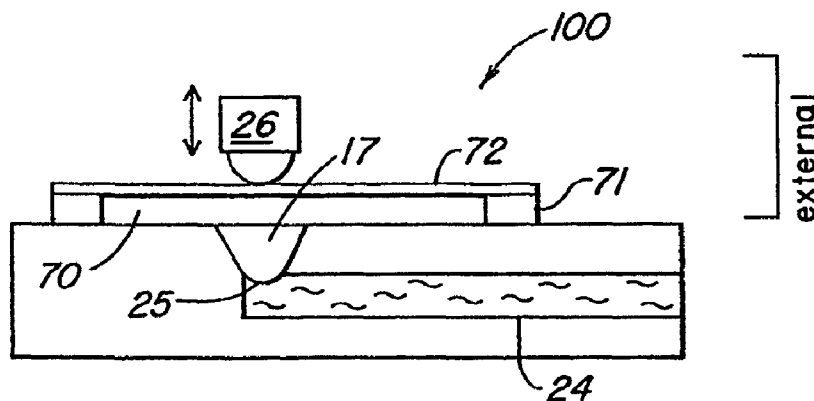

comprise a multi-stage sorting device for serially sorting streams of particles, in order to decrease the error rate.

13 Claims, 7 Drawing Sheets

Related U.S. Application Data

continuation of application No. 13/245,132, filed on Sep. 26, 2011, now Pat. No. 8,727,131, which is a continuation of application No. 12/499,254, filed on Jul. 8, 2009, now Pat. No. 8,567,608, which is a continuation of application No. 11/101,038, filed on Apr. 6, 2005, now Pat. No. 7,569,788, which is a division of application No. 10/329,008, filed on Dec. 23, 2002, now Pat. No. 6,976,590, which is a continuation-in-part of application No. 10/179,488, filed on Jun. 24, 2002, now Pat. No. 6,808,075.

(60) Provisional application No. 60/411,058, filed on Sep. 16, 2002, provisional application No. 60/373,256, filed on Apr. 17, 2002.

(51) **Int. Cl.**

B01L 3/00 (2006.01)
B07C 5/34 (2006.01)
F15C 5/00 (2006.01)
F16K 99/00 (2006.01)
G01N 15/14 (2006.01)
B07C 5/02 (2006.01)

(52) **U.S. Cl.**

CPC **B01L 3/502761** (2013.01); **B07C 5/02** (2013.01); **B07C 5/34** (2013.01); **F15C 5/00** (2013.01); **F16K 99/0001** (2013.01); **F16K 99/0019** (2013.01); **F16K 99/0028** (2013.01); **F16K 99/0046** (2013.01); **F16K 99/0048** (2013.01); **G01N 15/10** (2013.01); **G01N 15/14** (2013.01); **B01L 3/5027** (2013.01); **B01L 2200/0652** (2013.01); **B01L 2300/0654** (2013.01); **B01L 2300/0816** (2013.01); **B01L 2300/0877** (2013.01); **B01L 2400/0487** (2013.01); **G01N 2015/1075** (2013.01); **G01N 2015/1081** (2013.01); **G01N 2015/149** (2013.01); **G01N 2015/1477** (2013.01); **G01N 2015/1497** (2013.01); **Y10S 209/906** (2013.01); **Y10S 209/932** (2013.01)

(58) **Field of Classification Search**

CPC **F16K 99/0084**; **G01N 2015/1081**; **G01N 2015/149**; **G01N 15/1481**; **G01N 15/1484**; **G01N 2201/0253**; **B01L 3/5027**; **B01L 3/502715**; **B01L 3/50273**; **B01L 3/502746**; **B01L 3/502761**; **B01L 3/502792**; **B01L 2300/0819**; **B01L 2300/0861**; **B01L 2300/0877**; **B01L 2300/14**

See application file for complete search history.

(56) **References Cited**

U.S. PATENT DOCUMENTS

2,787,453 A * 4/1957 Hibshman B01D 3/24
 202/158
 2,850,940 A 9/1958 Opperman
 2,923,410 A * 2/1960 Tschmelitsch B03B 5/06
 209/484
 3,289,687 A 12/1966 Dunaway

3,362,421 A * 1/1968 Schaffer F15C 1/04
 137/828
 3,370,538 A 2/1968 Hines et al.
 3,495,253 A 2/1970 Richards
 3,506,654 A 4/1970 Fried
 3,508,654 A 4/1970 Glaetli
 3,508,655 A 4/1970 Kamentsky
 3,560,754 A 2/1971 Kamentsky
 3,785,390 A * 1/1974 Taylor F15C 1/14
 137/13
 3,791,517 A 2/1974 Friedman
 3,827,555 A 8/1974 Kamentsky et al.
 3,906,415 A 9/1975 Baker
 3,984,307 A 10/1976 Kamentsky et al.
 3,984,621 A 10/1976 Propst
 4,050,851 A 9/1977 Haavik
 4,147,621 A 4/1979 Giddings
 4,153,855 A 5/1979 Feingold
 4,175,662 A 11/1979 Zold
 4,284,499 A * 8/1981 Moudgil B03D 1/00
 209/166
 4,318,483 A 3/1982 Lombardo et al.
 4,344,844 A * 8/1982 Townley B03B 1/04
 209/1
 4,361,400 A 11/1982 Gray et al.
 4,365,719 A 12/1982 Kelly
 4,426,451 A 1/1984 Columbus
 4,445,696 A 5/1984 Raj et al.
 4,526,276 A 7/1985 Shoor et al.
 4,554,427 A 11/1985 Flick et al.
 4,572,664 A 2/1986 Hanson
 4,579,173 A 4/1986 Rosensweig et al.
 4,581,624 A 4/1986 O'Connor
 4,636,149 A 1/1987 Brown
 4,676,274 A 6/1987 Brown
 4,756,427 A 7/1988 Gohde et al.
 4,808,079 A 2/1989 Crowley et al.
 4,863,588 A * 9/1989 Herron B03B 5/26
 209/44
 4,908,112 A 3/1990 Pace
 4,936,465 A 6/1990 Zold
 4,939,081 A 7/1990 Figdor et al.
 4,963,498 A * 10/1990 Hillman B01F 5/0646
 356/28
 5,005,639 A 4/1991 Leland
 5,030,002 A 7/1991 North, Jr.
 5,065,978 A 11/1991 Albarda et al.
 5,092,972 A 3/1992 Ghowsi
 5,101,978 A 4/1992 Marcus
 5,193,688 A 3/1993 Giddings
 5,213,479 A 5/1993 Dardis et al.
 5,265,327 A 11/1993 Faris et al.
 5,271,724 A * 12/1993 van Lintel F15C 5/00
 137/554
 5,275,787 A 1/1994 Yuguchi et al.
 5,277,556 A * 1/1994 van Lintel F04B 43/046
 137/855
 5,395,588 A 3/1995 North, Jr. et al.
 5,486,335 A 1/1996 Wilding et al.
 5,498,392 A * 3/1996 Wilding B01D 61/18
 422/400
 5,541,072 A 7/1996 Wang et al.
 5,617,955 A * 4/1997 Tanner B03B 5/26
 209/458
 5,622,831 A 4/1997 Liberti et al.
 5,632,935 A * 5/1997 Yeoman B01D 3/163
 261/114.1
 5,637,496 A 6/1997 Thaler et al.
 5,699,157 A 12/1997 Parce
 5,726,026 A * 3/1998 Wilding B01D 67/0062
 366/DIG. 3
 5,726,404 A * 3/1998 Brody B01L 3/502738
 137/261
 5,777,649 A 7/1998 Otsuka et al.
 5,783,446 A 7/1998 Saul et al.
 5,789,045 A 8/1998 Wapner et al.
 5,795,727 A 8/1998 Bierre et al.
 5,837,200 A 11/1998 Diessel et al.

(56)

References Cited

U.S. PATENT DOCUMENTS

5,858,195	A *	1/1999	Ramsey	B01F 13/0076 204/450	7,452,725	B2	11/2008	Leary et al.
5,876,187	A	3/1999	Forster et al.			7,497,334	B2	3/2009	Tyvoll et al.
5,885,470	A	3/1999	Parce et al.			7,569,788	B2	8/2009	Deshpande et al.
5,932,100	A	8/1999	Yager et al.			7,584,857	B2	9/2009	Bohm et al.
5,976,336	A	11/1999	Dubrow et al.			7,612,355	B2	11/2009	Wu et al.
5,979,664	A	11/1999	Brodeur			7,820,427	B2	10/2010	Unger et al.
5,988,522	A	11/1999	Glezer et al.			7,863,035	B2	1/2011	Clemens et al.
5,998,212	A	12/1999	Corio et al.			7,963,399	B2	6/2011	Bohm et al.
6,033,191	A	3/2000	Kamper et al.			7,964,078	B2 *	6/2011	Lee B01L 3/502761 204/547
6,046,056	A	4/2000	Parce et al.			8,123,044	B2	2/2012	Johnson et al.
6,048,328	A	4/2000	Haller et al.			8,210,209	B2	7/2012	Gilbert et al.
6,048,734	A	4/2000	Burns et al.			8,252,604	B2	8/2012	Rigler
6,057,111	A	5/2000	Deiss et al.			8,268,245	B2 *	9/2012	Wahl B01L 3/502792 422/81
6,062,681	A	5/2000	Field et al.			8,408,399	B2	4/2013	Bohm et al.
6,068,752	A *	5/2000	Dubrow	B01L 3/50273 204/450	8,567,608	B2 *	10/2013	Deshpande B07C 5/34 209/552
6,086,740	A *	7/2000	Kennedy	B01L 3/502715 204/601	8,609,039	B2 *	12/2013	Zhou B01L 3/5025 422/500
6,102,530	A	8/2000	Kim et al.			8,623,294	B2 *	1/2014	Asogawa B01L 3/50273 422/50
6,120,666	A	9/2000	Jacobson et al.			8,623,295	B2	1/2014	Gilbert et al.
6,145,247	A	11/2000	McKinnis			8,678,192	B1 *	3/2014	Pung B03B 5/26 209/18
6,152,181	A	11/2000	Wapner et al.			8,691,164	B2	4/2014	Butler et al.
6,196,525	B1	3/2001	Ganan-Calvo			8,723,140	B2	5/2014	Kiesel et al.
6,203,291	B1	3/2001	Stemme et al.			8,727,131	B2	5/2014	Desphande et al.
6,214,556	B1	4/2001	Olek et al.			8,844,571	B2	9/2014	Golling et al.
6,221,654	B1	4/2001	Quake et al.			8,895,311	B1	11/2014	Handique et al.
6,273,553	B1	8/2001	Kim et al.			9,011,797	B2	4/2015	Gilbert et al.
6,280,967	B1	8/2001	Ransom et al.			9,074,978	B2	7/2015	Lo et al.
6,318,970	B1	11/2001	Backhouse			9,149,806	B2 *	10/2015	Collins G01N 15/1031
6,337,740	B1 *	1/2002	Parce	G01N 27/44721 356/344	9,194,786	B2	11/2015	Foster et al.
6,360,775	B1	3/2002	Barth et al.			9,448,157	B2 *	9/2016	Ito B01L 3/502761
6,431,212	B1	8/2002	Hayenga et al.			9,550,215	B2	1/2017	Deshpande et al.
6,432,630	B1	8/2002	Blankenstein			2002/0005354	A1	1/2002	Spence et al.
6,454,862	B1	9/2002	Yoshida et al.			2002/0058332	A1	5/2002	Quake et al.
6,455,280	B1	9/2002	Edwards et al.			2002/0093641	A1	7/2002	Ortyn et al.
6,481,453	B1	11/2002	O'Connor et al.			2002/0166585	A1	11/2002	O'Connor et al.
6,482,652	B2	11/2002	Furlong et al.			2003/0027225	A1	2/2003	Wada et al.
6,507,391	B2	1/2003	Riley et al.			2004/0037739	A1	2/2004	McNeely et al.
6,524,790	B1	2/2003	Kopf-Sill et al.			2004/0180426	A1	9/2004	Maher et al.
6,532,061	B2	3/2003	Ortyn et al.			2004/0233424	A1	11/2004	Lee et al.
6,540,895	B1	4/2003	Spence et al.			2006/0170912	A1	8/2006	Mueth et al.
6,561,224	B1	5/2003	Cho			2006/0177348	A1	8/2006	Yasuda et al.
6,592,821	B1	7/2003	Wada et al.			2006/0278288	A1 *	12/2006	Gilbert B01L 3/502738 137/827
6,597,438	B1	7/2003	Cabuz et al.			2007/0065808	A1	3/2007	Bohm et al.
6,629,820	B2	10/2003	Komelsen			2008/0070311	A1	3/2008	Li
6,657,730	B2	12/2003	Pfau et al.			2008/0213821	A1 *	9/2008	Liu B01L 3/502761 435/39
6,739,576	B2	5/2004	O'Connor et al.			2009/0283452	A1	11/2009	Lean et al.
6,799,681	B1 *	10/2004	Warren	B03B 5/26 209/268	2010/0032350	A1	2/2010	Deshpande et al.
6,802,342	B2	10/2004	Fernandes et al.			2010/0133151	A1	6/2010	Bohm et al.
6,803,194	B1	10/2004	Keck et al.			2011/0005978	A1	1/2011	Bohm et al.
6,808,075	B2	10/2004	Bohm et al.			2011/0030808	A1 *	2/2011	Chiou B01L 3/502738 137/13
6,821,484	B1	11/2004	Gregersen			2012/0006727	A1	1/2012	Bohm et al.
6,830,936	B2 *	12/2004	Anderson	B01F 11/0071 422/504	2012/0012508	A1	1/2012	Deshpande et al.
6,877,528	B2	4/2005	Gilbert et al.			2012/0015442	A1	1/2012	Gilbert et al.
6,976,590	B2	12/2005	Deshpande et al.			2012/0153185	A1 *	6/2012	Ito B01L 3/502761 250/458.1
7,024,281	B1	4/2006	Unno			2012/0258488	A1	10/2012	Abilez et al.
7,069,943	B2	7/2006	Gilbert et al.			2013/0083315	A1	4/2013	Lo et al.
7,075,652	B1	7/2006	Sarvazyan et al.			2014/0251879	A1	9/2014	Deshpande et al.
7,080,664	B1 *	7/2006	Ayer	F15C 1/008 137/826	2014/0339445	A1	11/2014	Sharpe et al.
7,104,405	B2	9/2006	Bohm et al.			2015/0298122	A1 *	10/2015	Zeng B01L 3/502738 435/309.1
7,118,910	B2 *	10/2006	Unger	B01L 3/502707 137/597	2015/0375227	A1	12/2015	Quake et al.
7,157,274	B2	1/2007	Bohm et al.			2016/0040226	A1 *	2/2016	Mehta C12Q 1/6874 506/2
7,157,275	B2	1/2007	Guarino et al.						
7,220,594	B2	5/2007	Foster et al.						
7,258,774	B2	8/2007	Chou et al.						
7,303,727	B1	12/2007	Dubrow et al.						
7,355,699	B2	4/2008	Gilbert et al.						
7,389,879	B2	6/2008	Tyvoll et al.						

(56)

References Cited

U.S. PATENT DOCUMENTS

2016/0158758 A1* 6/2016 Johnson C12N 5/0081
435/3

FOREIGN PATENT DOCUMENTS

EP	1065378	A2	1/2001
GB	2140128	A	11/1984
GB	2229649	A	10/1990
JP	S49-046274		5/1974
JP	S61-137062		6/1986
JP	S63-259466		10/1988
JP	H01-170853		7/1989
JP	H03-043070		2/1991
JP	H05-506180		9/1993
JP	H06-507241		8/1994
JP	H08-332074		12/1996
JP	H09-141124		6/1997
JP	H11-508182		7/1999
JP	2001-521755	A	11/2001
JP	2002-503334	A	1/2002
JP	2004-505272	A	2/2004
WO	WO-91/14505	A1	10/1991
WO	WO-91/15750	A1	10/1991
WO	WO-98/07069	A1	2/1998
WO	WO-98/10267	A1	3/1998
WO	WO-98/52691	A1	11/1998
WO	WO-99/23471	A1	5/1999
WO	WO-2000070080	A1	11/2000
WO	WO-02/10713	A2	2/2002
WO	WO-02/44689	A2	6/2002
WO	03/089158	A1	10/2003

OTHER PUBLICATIONS

Communication issued in European Application No. 03 726 391.0-2204, dated Apr. 12, 2010.

Development of an Electromagnetically Actuated Mercury Microvalve, Douglas R. Adkins and C. Channy Wong, DSC—vol. 66, Micro-Electro-Mechanical Systems (MEMS)—1998 (ASME 1998), pp. 133-137.

Examination Report issued in Australian Application No. 2003228630, dated Feb. 11, 2008.

Examination Report issued in Australian Application No. 2003270722, dated Aug. 26, 2009.

Examination Report issued in Australian Application No. 2010200179, dated Mar. 22, 2011.

Examination Report issued in Indian Application No. 1587/KOLNP/2004, dated Jul. 15, 2010.

First Office Action issued in Chinese Application No. 03825178.7, dated Jun. 27, 2008.

International Preliminary Examination Report issued in International Application No. PCT/US03/12359, dated Nov. 12, 2003.

International Preliminary Examination Report issued in International Application No. PCT/US03/12368, dated Aug. 25, 2004.

International Preliminary Examination Report issued in International Application No. PCT/US03/29198, dated Feb. 21, 2006.

International Search Report issued in International Application No. PCT/US03/12359, dated Jun. 28, 2003.

International Search Report issued in International Application No. PCT/US03/12368, dated Aug. 21, 2003.

International Search Report issued in International Application No. PCT/US03/29198, dated Jun. 10, 2005.

LookSmart computer search for “ferrofluid” indicating The Design of a Ferrofluid Magnetic Pipette, Sep. 3, 1998, 3 pages.

Magnetic Fluids, Magnetic Forces and Pumping Mechanisms, by Constance Warren Miller, Jan. 1974, cover page and p. 91-109.

Magnetic Fluids: Magnetic Forces and Pumping Mechanisms, Constance Warren Miller, Jan. 1974, p. 1 (pp. 91-109 of this reference were previously disclosed).

Microactuation by Continuous Electrowetting Phenomenon and Silicon Deep Rie Process, Junghoon Lee and Chang-Jin “CJ” Kim, DSC—vol. 66, Micro-Electro-Mechanical Systems (MEMS)—1998 (ASME 1998), pp. 475-480.

Notice of Allowance issued in U.S. Appl. No. 12/821,790, dated Apr. 14, 2015.

Office Action in Japanese Application No. 2004-536583, dated Sep. 29, 2009.

Office Action issued in Canadian Application No. 2,482,869, dated Dec. 17, 2010.

Office Action issued in Canadian Application No. 2,482,869, dated Feb. 16, 2010.

Office Action issued in Canadian Application No. 2,482,869, dated Jul. 26, 2012.

Office Action issued in Canadian Application No. 2,482,869, dated Sep. 13, 2011.

Office Action issued in Chinese Application No. 03814212.0, dated Apr. 25, 2008.

Office Action issued in Chinese Application No. 03814212.0, dated Feb. 20, 2009.

Office Action issued in Chinese Application No. 200910168699.1, dated Jun. 21, 2012.

Office Action issued in Israeli Application No. 167266, dated Sep. 28, 2010.

Office Action issued in Japanese Application No. 2003-585899, dated Jan. 11, 2008.

Office Action issued in Japanese Application No. 2003-585899, dated Jun. 6, 2007.

Office Action issued in Japanese Application No. 2007-315437, dated May 11, 2011.

Office Action issued in Japanese Application No. 2007-315437, dated May 12, 2010.

Office Action issued in U.S. Appl. No. 10/329,008, dated May 23, 2005.

Office Action issued in U.S. Appl. No. 10/329,008, dated Nov. 30, 2004.

Office Action issued in U.S. Appl. No. 10/664,587, dated Feb. 9, 2006.

Office Action issued in U.S. Appl. No. 10/664,587, dated Jun. 13, 2005.

Office Action issued in U.S. Appl. No. 10/664,587, dated Nov. 30, 2004.

Office Action issued in U.S. Appl. No. 11/101,038, dated Feb. 22, 2008.

Office Action issued in U.S. Appl. No. 11/101,038, dated Jul. 9, 2007.

Office Action issued in U.S. Appl. No. 11/101,038, dated Jun. 5, 2006.

Office Action issued in U.S. Appl. No. 12/499,254, dated Jan. 11, 2012.

Office Action issued in U.S. Appl. No. 12/499,254, dated Jul. 26, 2012.

Office Action issued in U.S. Appl. No. 12/499,254, dated Mar. 9, 2010.

Office Action issued in U.S. Appl. No. 12/821,790, dated Dec. 2, 2013.

Office Action issued in U.S. Appl. No. 12/821,790, dated Jun. 6, 2012.

Office Action issued in U.S. Appl. No. 12/821,790, dated Oct. 1, 2012.

Office Action issued in U.S. Appl. No. 12/821,790, dated Oct. 1, 2014.

Office Action issued in U.S. Appl. No. 13/245,132, dated Jun. 10, 2013.

Office Action issued in U.S. Appl. No. 13/245,132, dated Nov. 6, 2012.

Office Action issued in U.S. Appl. No. 13/849,365, dated Jan. 2, 2015.

Office Action issued in U.S. Appl. No. 11/603,444, dated Dec. 23, 2009.

Office Action issued in U.S. Appl. No. 12/537,802 dated Jun. 18, 2010.

(56)

References Cited

OTHER PUBLICATIONS

Second Office Action issued in Chinese Application No. 03825178.7, dated Mar. 20, 2009.

Study of MHD (Magnetohydrodynamic) Micropump, Kazuo Hosokawa, Isao Shimoyama and Hirohumi Miura, Paper No. 92-0446, 1993, pp. 205-210, with attached translation (8 pages).

Supplementary European Search Report issued in European Application No. 03726391.0-2204, dated Oct. 6, 2009.

Supplementary European Search Report issued in European Application No. 03752432.9, dated Aug. 14, 2009.

The Design of a Ferrofluid-Magnetic Pipet by Nancy E. Greivell, Jun. 1995, cover page and p. 3-5 and 21-56.

Third Office Action issued in Chinese Application No. 03825178.7, dated Sep. 18, 2009.

Written Opinion issued in Singapore Application No. 200701943-3, dated Dec. 1, 2009.

Search Information Statement issued in Australian Application No. 2010200179, dated Mar. 22, 2011.

International Search Report issued in International Application No. PCT/US03/12360, dated Oct. 30, 2003.

International Preliminary Examination Report issued in International Application No. PCT/US03/12360, completed Jul. 21, 2004.

Notice of Allowance issued in U.S. Appl. No. 13/245,132, dated Jan. 2, 2014.

International Search Report issued in International Application No. PCT/US03/12359, dated Nov. 12, 2003.

Office Action issued in U.S. Appl. No. 14/281,303, dated Apr. 18, 2016.

Examination Report by Brazilian Patent Office for Brazilian Application No. PI0309321-2 dated Aug. 9, 2016 (English translation).

* cited by examiner

Fig. 1

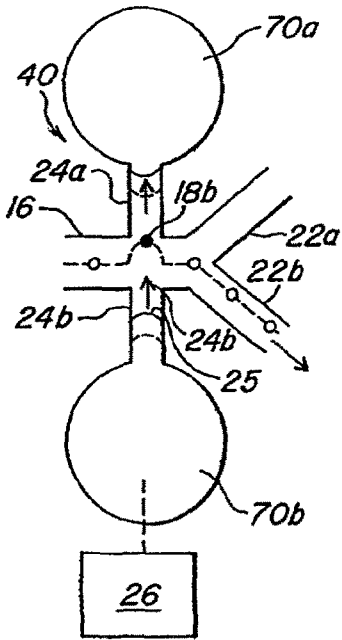
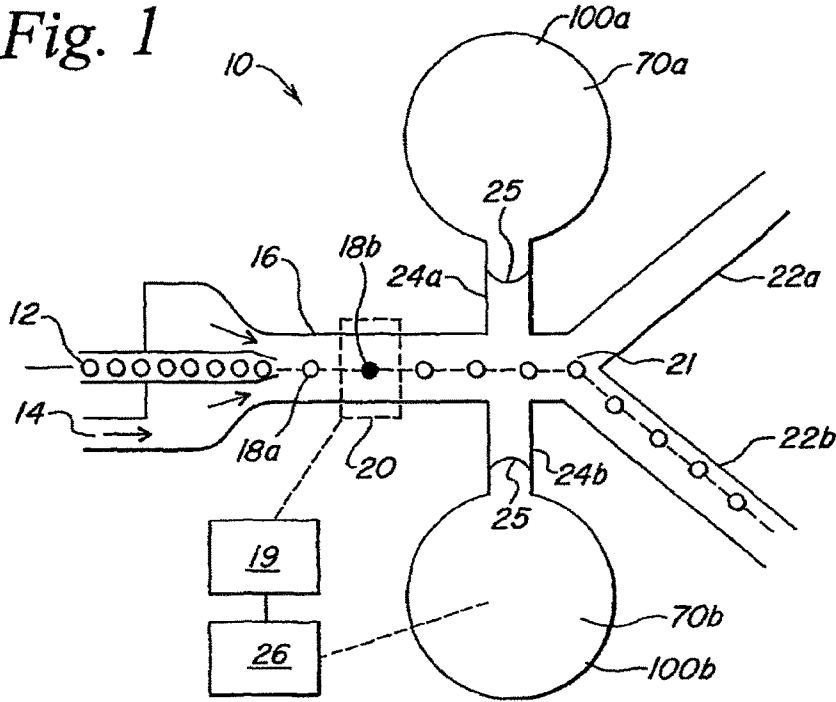

Fig. 2

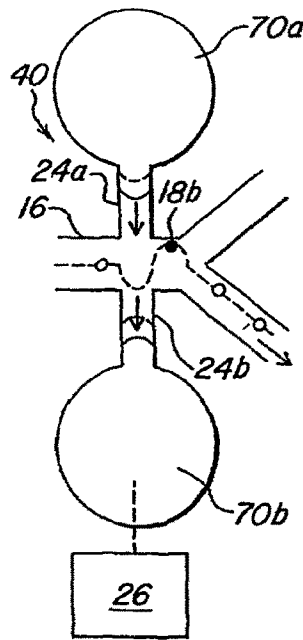

Fig. 3

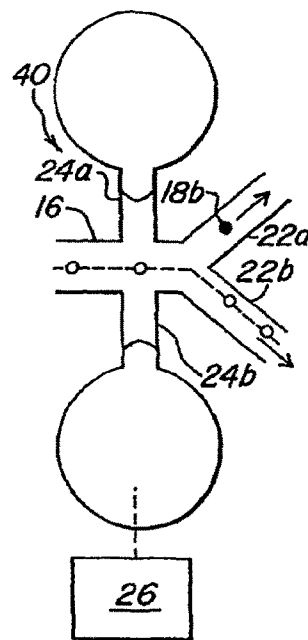

Fig. 4

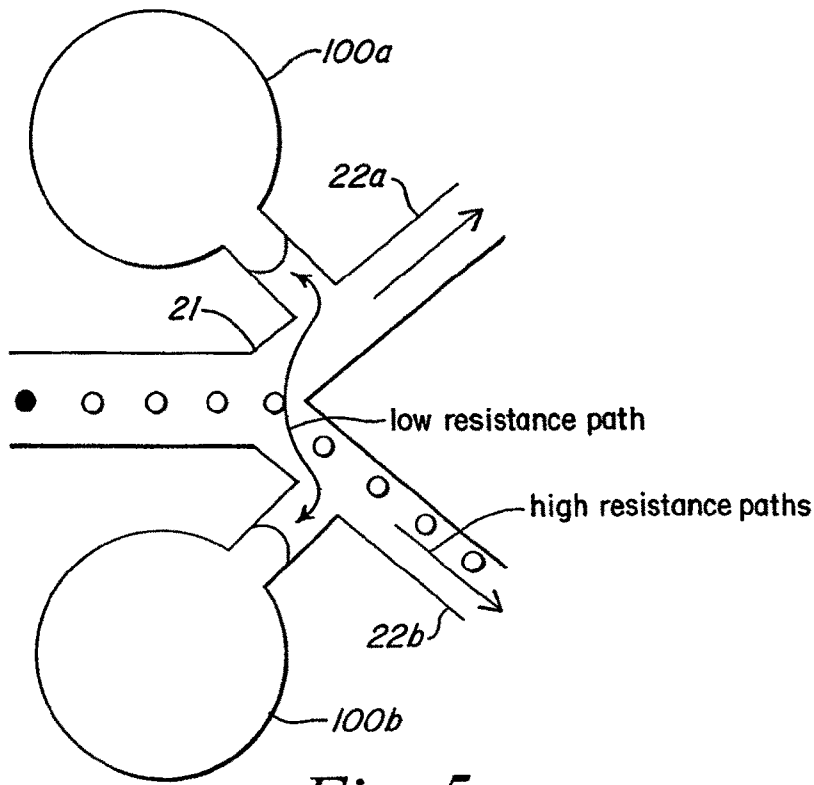

Fig. 5

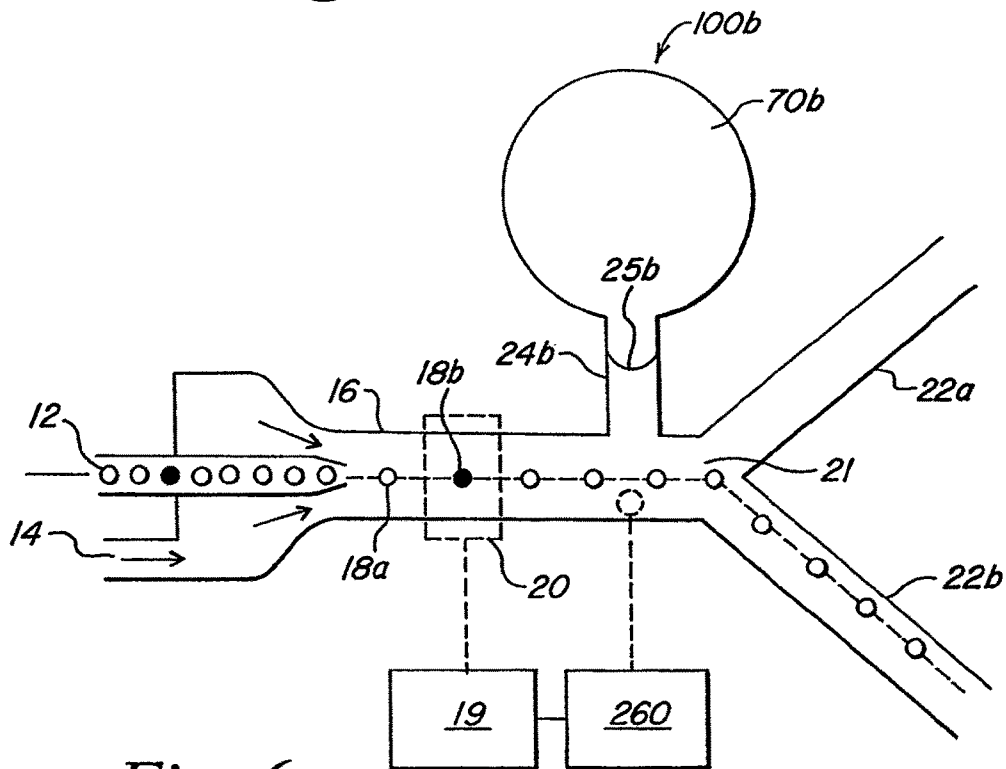

Fig. 6

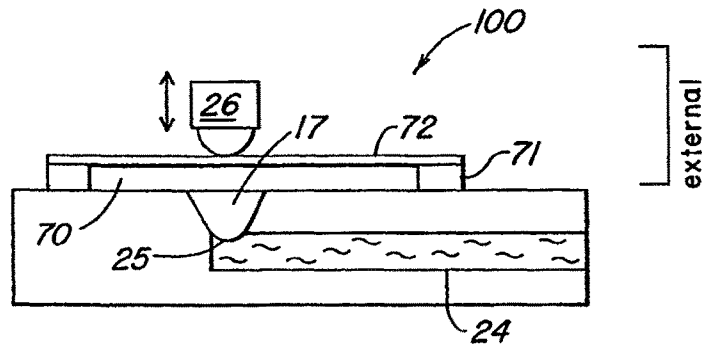

Fig. 7

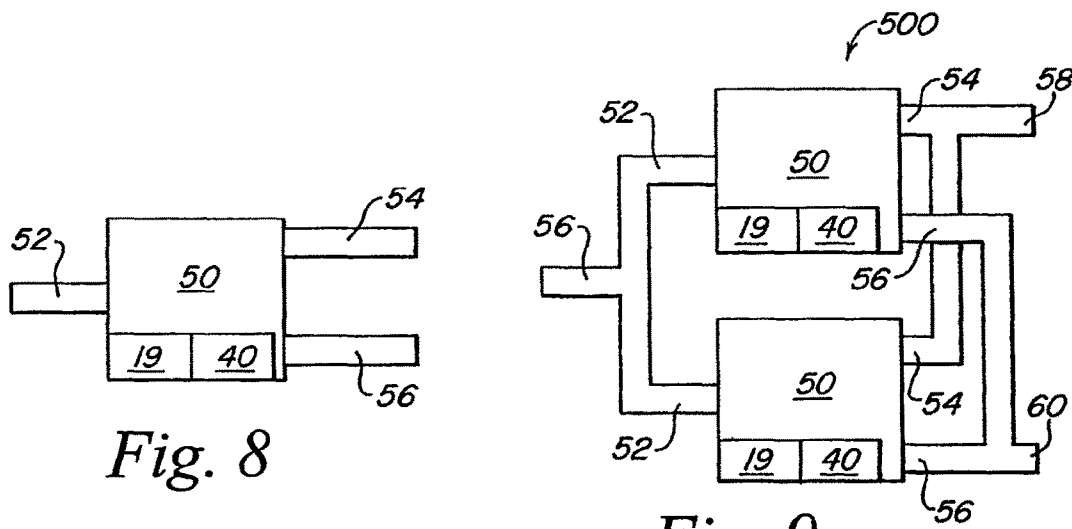

Fig. 8

Fig. 9

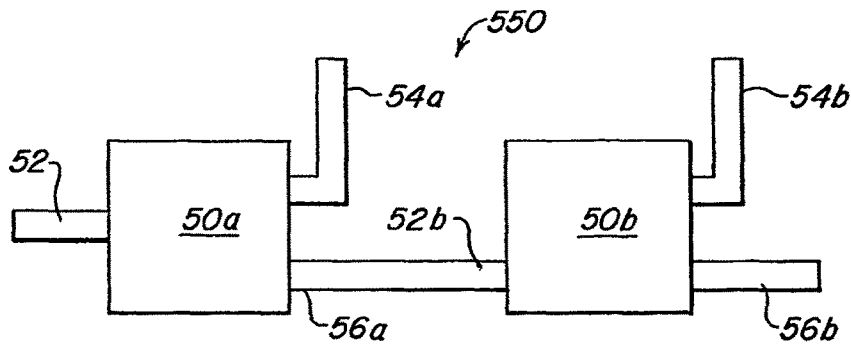

Fig. 10

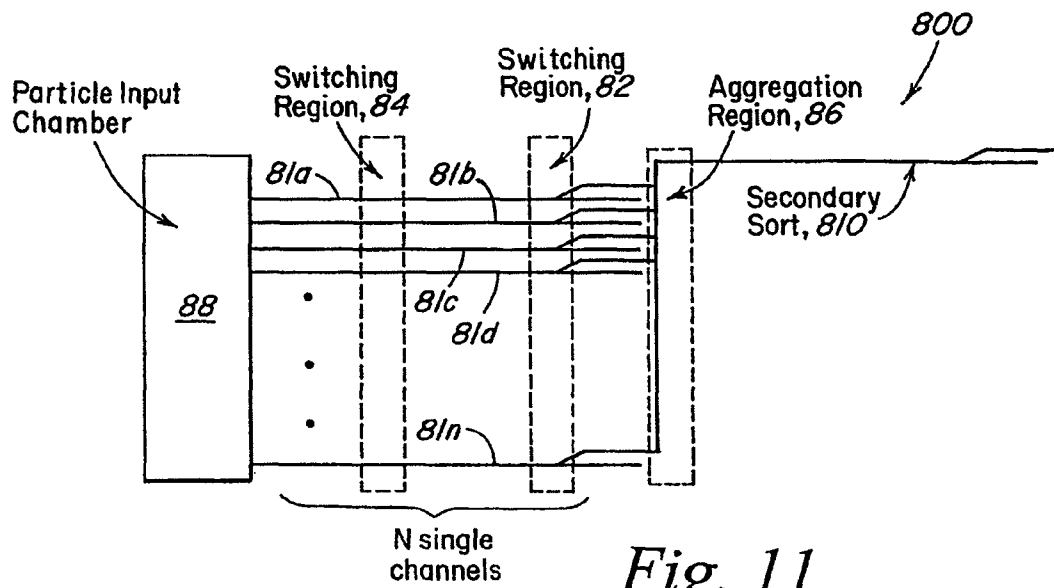

Fig. 11

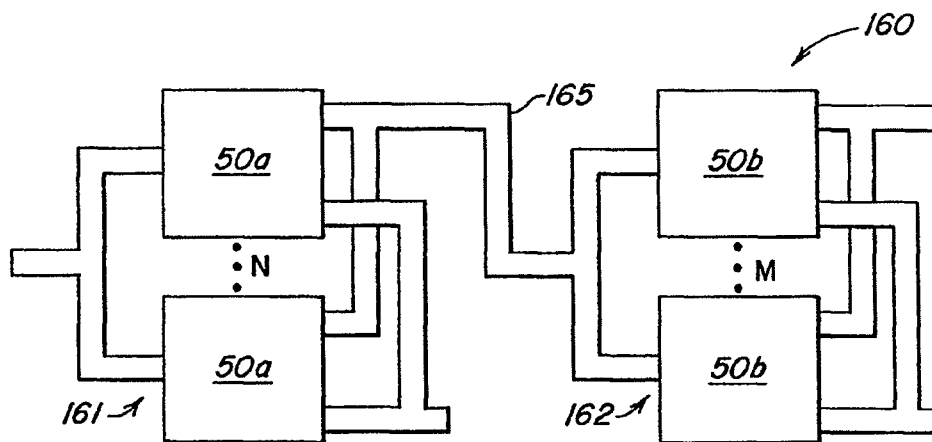

Fig. 12

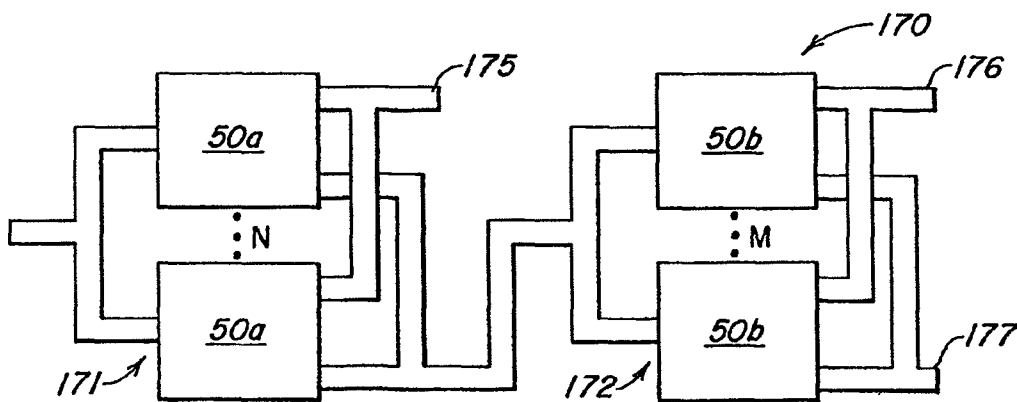

Fig. 13

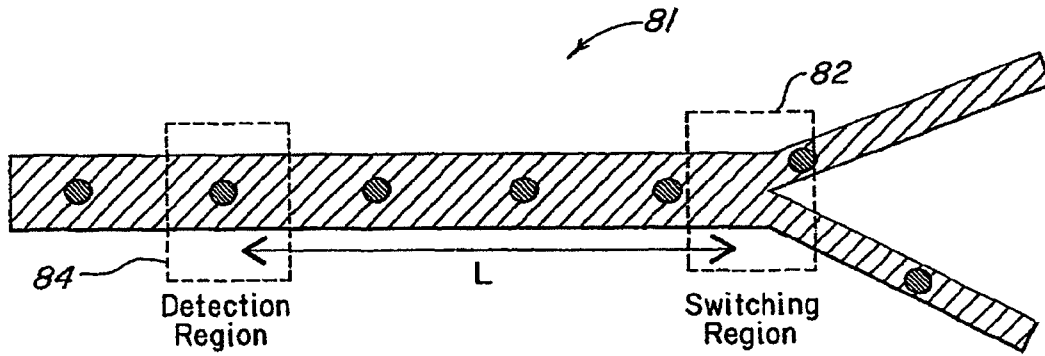
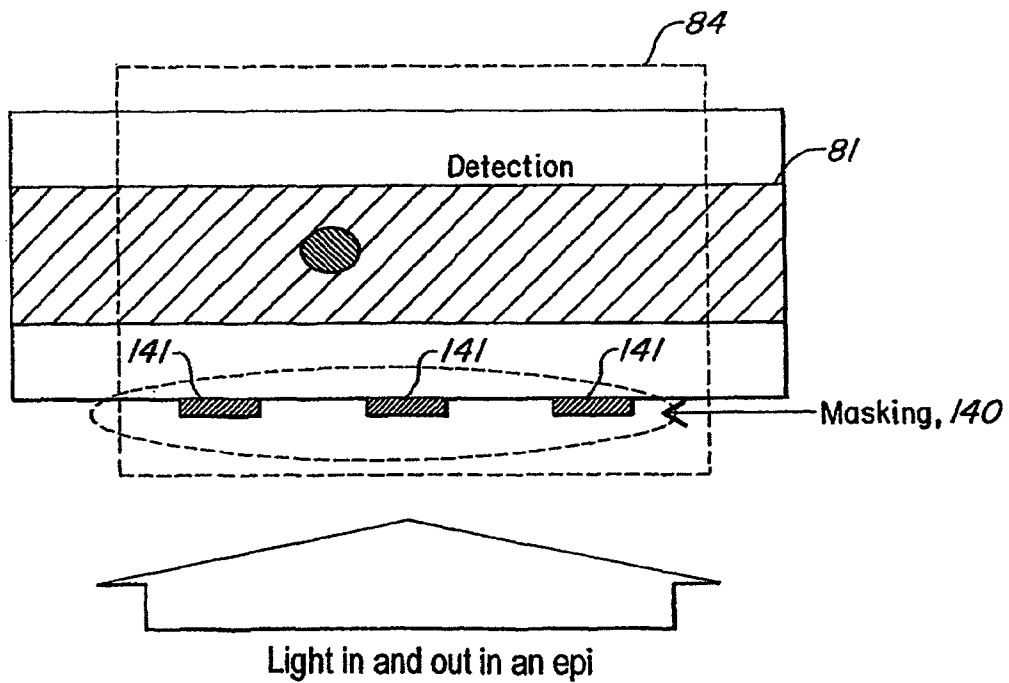

Fig. 14a



Light in and out in an epi

Fig. 14b

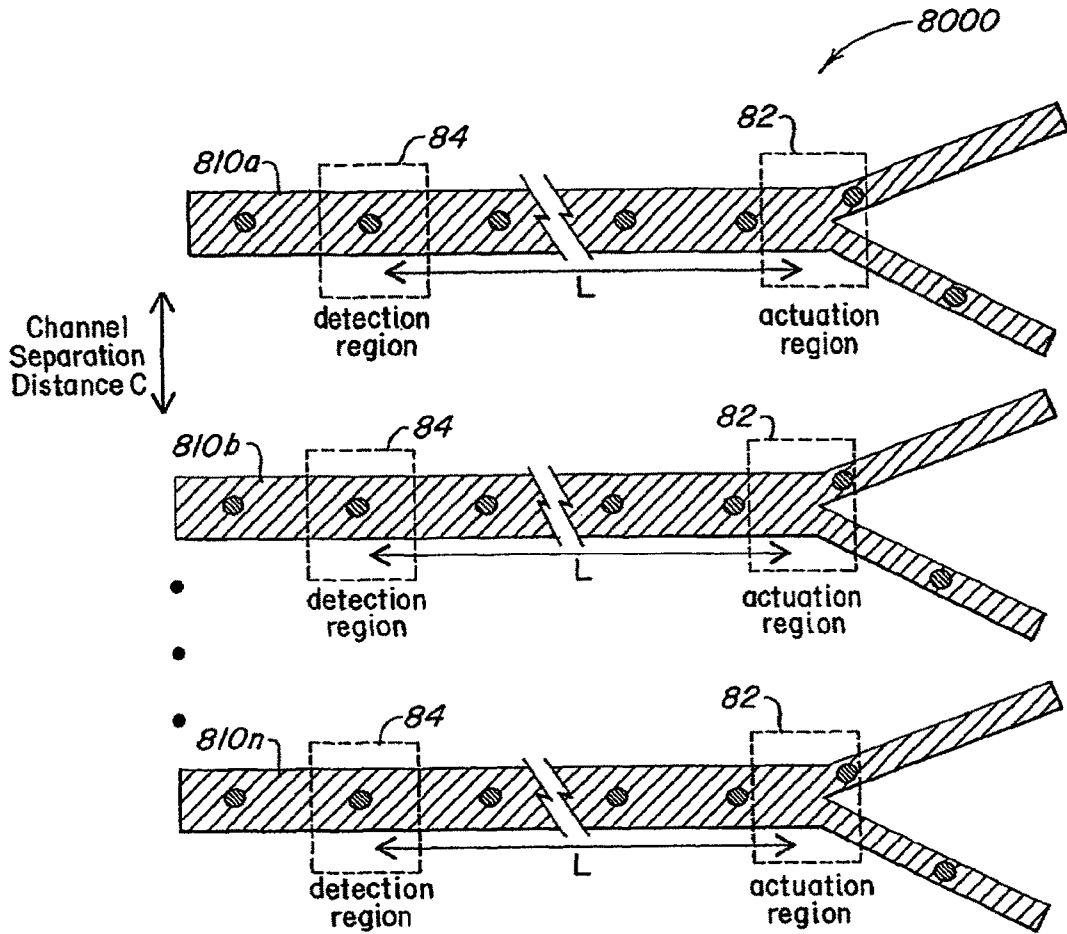

Fig. 15

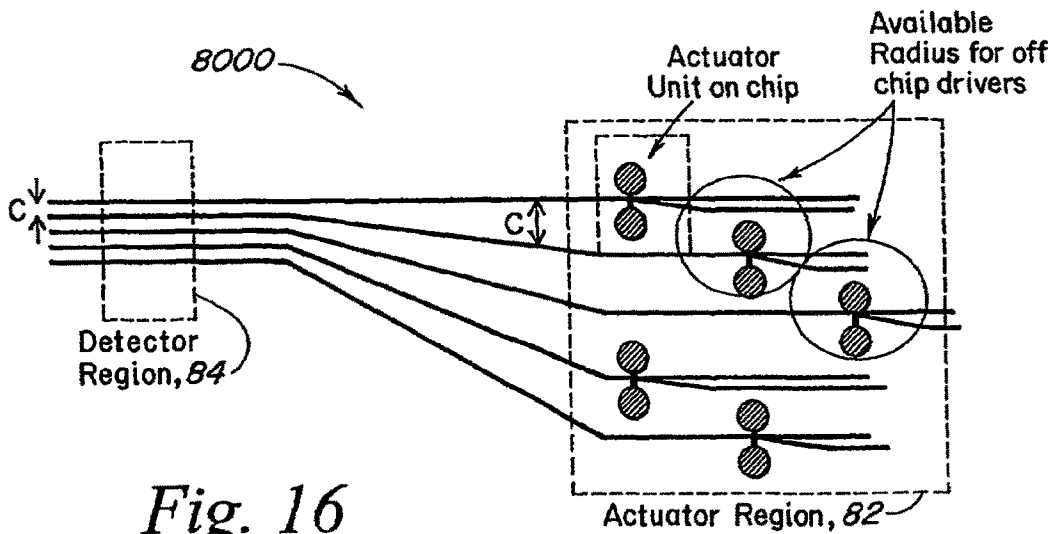

Fig. 16

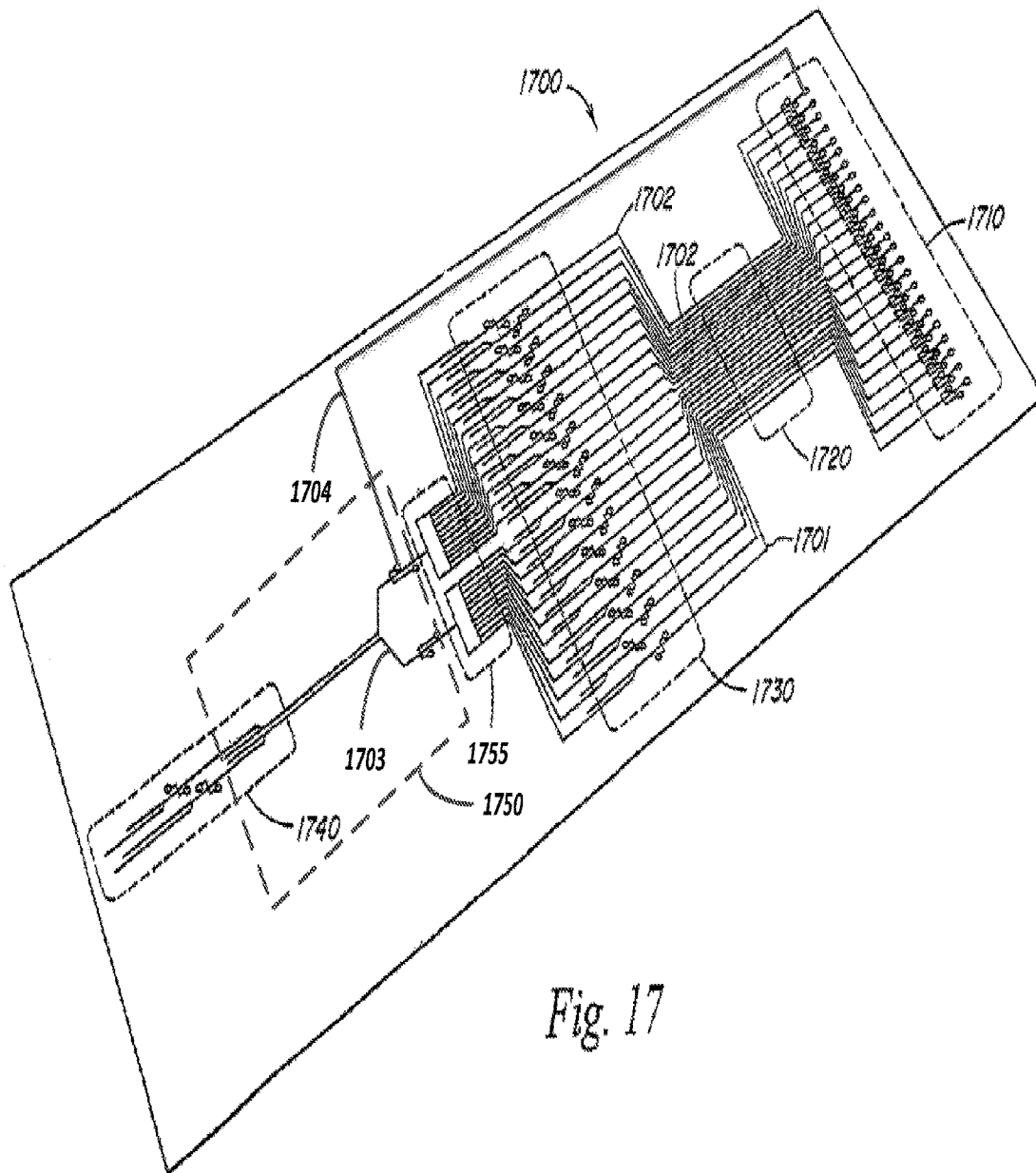

Fig. 17

METHOD AND APPARATUS FOR SORTING PARTICLES

RELATED APPLICATIONS

This application is a Continuation of U.S. patent application Ser. No. 14/281,303, entitled "Method and Apparatus for Sorting Particles" filed May 19, 2014, which, in turn, is a Continuation of U.S. patent application Ser. No. 13/245,132, filed Sep. 26, 2011, which, in turn, is a continuation of U.S. patent application Ser. No. 12/499,254, filed Jul. 8, 2009 which, in turn, is a continuation of U.S. patent application Ser. No. 11/101,038, filed Apr. 6, 2005, which, in turn, is a divisional of Ser. No. 10/329,008, filed Dec. 23, 2002, which claims priority to U.S. Provisional Patent Application Ser. No. 60/411,058, filed Sep. 16, 2002, and is a continuation-in-part of U.S. patent application Ser. No. 10/179,488, filed Jun. 24, 2002, which claims priority to U.S. Provisional Patent Application No. 60/373,256, filed Apr. 17, 2002, the contents of each application is incorporated herein by reference in their entirety.

FIELD OF THE INVENTION

The invention relates to a method and apparatus for the sorting of particles in a suspension, where the input flow path of a sorting module can be split into several output channels. More particular, the invention relates to a particle sorting system in which a plurality of sorting modules are interconnected as to yield an increased particle throughput.

BACKGROUND OF THE INVENTION

In the fields of biotechnology, and especially cytology and drug screening, there is a need for high throughput sorting of particles. Examples of particles that require sorting are various types of cells, such as blood platelets, white blood cells, tumorous cells, embryonic cells and the like. These particles are especially of interest in the field of cytology. Other particles are (macro) molecular species such as proteins, enzymes and poly-nucleotides. This family of particles is of particular interest in the field of drug screening during the development of new drugs.

Methods and apparatus for particle sorting are known, and the majority described in the prior art work in the condition where the particles are suspended in a liquid flowing through a channel network having at least a branch point downstream and are operated according to the detect-decide-deflect principle. The moving particle is first analyzed for a specific characteristic, such as optical absorption, fluorescent intensity, size etc. Depending on the outcome of this detection phase, it is decided how the particle will be handled further downstream. The outcome of the decision is then applied to deflect the direction of specific particle towards a predetermined branch of the channel network.

Of importance is the throughput of the sorting apparatus, i.e. how many particles can be sorted per unit of time. Typical sorting rates for sorters employing flows of particle suspension in closed channels are in the range from a few hundred particles per second to thousands of particles per second, for a single sorting unit.

An example of a sorting device is described in U.S. Pat. No. 4,175,662, the contents of which are herein incorporated by reference (hereinafter referred to as the '662 patent). In the '662 patent, a flow of particles, cells in this case, flows through the center of a straight channel, which branches into two perpendicular channels at a branching point downstream

(T-branch). The entering particles are surrounded by a sheath of compatible liquid, keeping the particles confined to the center of the channel. In normal conditions, the flow ratio through the two branches is adjusted so that the particles automatically flow through one of the branches. In a section of the channel a characteristic of the particles is determined using a detector, which can be an optical system (detection phase). The detector generates a signal when the detector detects a particle possessing a predetermined characteristic in the decision phase. Once a particle is detected, a deflector is activated for deflecting the particle in a deflection phase. In this case, the deflector comprises an electrode pair, positioned in the branch of the channel where the particles normally flow through in the inactivated state of the deflector. By the application of current pulses, the aqueous liquid is electrolysed, yielding a gas bubble evolving between the electrode pair. As the gas bubble increases in size, the flow rate through this branch is reduced during the evolving phase. After the current pulse is applied, the bubble growth stops and the gas bubble is carried along with the flow. As a result, the flow through the specific branch is momentarily reduced and the particle of interest changes paths and flows down the other branch.

The device of the '662 patent is effective for sorting particles. However one serious drawback is that gas bubbles are created which potentially can accumulate at certain points of the fluidic network. This bubble generation can clog the flow channels, yielding erroneous sorting. Another drawback is that the generated gasses (mostly oxygen and hydrogen) and ionic species (mostly OH⁻ and H⁺) influence the particles flowing through the branch with the electrode pair. In addition, cells and delicate proteins such as enzymes are very fragile and can be destroyed by the fouling constituents co-generated with the gas bubble. Another drawback is the complexity of the overall sorting apparatus. In particular, the micro electrode construction is very complex to mount and assemble in the small channels of the system. As a result, the cost of a sorting unit is relatively large.

Another example of a particle sorting system of the prior art is disclosed in U.S. Pat. No. 3,984,307, the contents of which are herein incorporated by reference (hereinafter the '307 patent). In the '307 patent, the particles are flowing, confined by a flowing sheath liquid, through the center of a channel. After passing a detector section, the channel branches into two channels forming an acute angle therebetween (e.g., Y-branch). Just before the branching point, an electrically activated transducer is located in the channel for deflecting a specific particle having an appropriate, predetermined characteristic. The transducer described is a piezo actuator or ultrasonic transducer, yielding upon electrical activation a pressure wave in the channel. The generated pressure wave momentarily disturbs the flow in one branch thus deflecting the particle of interest into the other branch.

In the device of the '307 patent, as in the previous discussed device, the deflector is incorporated within the channel system, resulting in relatively large construction costs. Another drawback of this device is the deflector principle used. The generated pressure waves are not confined to the branching point, but rather propagate upstream into the detector section, as well as down both branches. This influences the overall flow through the channel. This is particularly a drawback if sorters of this type are connected either in series or in parallel, as is typically done to construct a high throughput sorting system. Pressure waves generated in one sorter can then influence the flows and deflection of particles in neighboring sorter units.

Another sorter is described in U.S. Pat. No. 4,756,427, the contents of which are herein incorporated by reference. This sorter is analogous to the sorter in the '662 patent. In this case, however, the flow in one branch is disturbed by momentarily changing the resistance of the branch. The resistance is changed by changing the height of the branch channel by an external actuator. In the preferred embodiment, this external actuator is a piezo disc glued on top of the channel, causing it to move downwards upon activation.

Although the construction of the sorter described in the '427 patent is less complex than the previously described sorter structures, it is still problematic to couple multiple sorter modules of the described type together to increase the sorting rate. This is, as in the sorter described in the '307 patent because of the generated pressure waves causing interference with other sorter modules.

Another particle sorting device is described in U.S. Pat. No. 5,837,200, the contents of which are herein incorporated by reference. The '200 patent describes a sorting device that uses a magnetic deflection module to classify or select particles based on their magnetic properties. The '200 patent further describes processing and separating individual particle streams in parallel.

SUMMARY OF THE INVENTION

The present invention provides a method and apparatus for sorting particles moving through a closed channel system of capillary size. The particle sorting system of the invention provides a sorting module that can be assembled at low cost while providing an accurate means of sorting large amounts of particles per unit of time. The particle sorting system may include a plurality of closely coupled sorting modules which are combined to further increase the sorting rate. The particle sorting system may comprise a multi-stage sorting device for serially sorting streams of particles, in order to decrease the error rate.

The particle sorting system implements an improved fluidic particle switching method and switching device according to the present invention. The particle sorting system comprises a closed channel system of capillary size for sorting particles. The channel system comprises a first supply duct for introducing a stream of particles and a second supply duct for supplying a carrier liquid. The first supply duct forms a nozzle to introduce a stream of particles into the flow of carrier liquid. The first supply duct and the second supply duct are in fluid communication with a measurement duct, which branches into a first branch and a second branch at a branch point. A measurement region is defined in the measurement duct and is associated with a detector to sense a predetermined characteristic of particles in the measurement region. Two opposed bubble valves are positioned in communication with the measurement duct and are spaced opposite each other. The bubble valves communicate with the measurement duct through a pair of opposed side passages. Liquid is allowed to partly fill these side passages to form a meniscus therein which interfaces the carrier liquid with the reservoir of the bubble valves. An external actuator is also provided for actuating one of the bubble valves. When the external actuator is activated, the pressure in the reservoir of the activated bubble valve increases, deflecting the meniscus and causing a flow disturbance in the measurement duct to deflect the flow therein.

When a sensor located in the measuring region senses a predetermined characteristic in a particle flowing through the measurement region, the sensor produces a signal in response to the sensed characteristic. The external actuator

is responsive to the sensor to cause a pressure pulse in a compression chamber of a first bubble valve to deflect the particle with the predetermined characteristic, causing the selected particle to flow down the second branch duct.

In one aspect, the invention comprises a method of sorting particles including the steps of providing a measurement duct having an inlet and a branching point at which the duct separates into two branch ducts, and conducting a stream of fluid into the duct inlet with a stream of particles suspended therein, such that the particles normally flow through a first one of the branch ducts and providing upstream from the branching point two opposing side passages for momentarily deflecting the stream in the duct. A first one of the side passages is hydraulically connected to a compression chamber of a first bubble valve, which is acted upon by an external actuator for varying the pressure therein. A second of the side passages is hydraulically connected with a buffer chamber of a second bubble valve for absorbing pressure variations. The method further comprises providing a measurement station along the measurement duct upstream of the side passages for sensing a predetermined characteristic of particles in the stream and for producing a signal when the predetermined characteristic is sensed. The method further comprises the step of, in response to sensing the predetermined characteristic, activating the external actuator for creating a flow disturbance in the duct between the side passages, thereby deflecting the particle having the predetermined characteristics and causing the selected particle to flow down the second branch duct.

In further aspects of the invention, the particle sort rate is respectively increased or the type of particles sorted being increased, by respectively connecting a plurality of sorting modules in parallel or serially connecting a plurality of sorting modules in a binary tree like configuration.

According to one aspect of the invention, a particle sorting system is provided. The particles sorting system comprises a first duct for conveying a stream of suspended particles confined in a carrier liquid, comprising an inlet, a first outlet and a second outlet, a sensor for sensing a predetermined characteristic in a particle, a side channel in communication with the first duct, a sealed chamber positioned adjacent to the side channel, wherein the carrier fluid forms a meniscus in the side channel to separate the sealed chamber from the carrier fluid; and an actuator. The actuator modifies the pressure in the sealed chamber to deflect the meniscus when the sensor senses the predetermined characteristic. The deflection of the meniscus causes the particle having the predetermined characteristic to flow into the second outlet while particles that do not have the predetermined characteristic flow into the first outlet.

BRIEF DESCRIPTION OF THE DRAWINGS

FIG. 1 is a schematic view of a particle sorting system according to an illustrative embodiment of the invention.

FIGS. 2 through 4 illustrate the operation of the particle sorting system of FIG. 1.

FIG. 5 illustrates a particle sorting system showing alternate positions for the actuator chamber and the buffer chamber.

FIG. 6 illustrates the particle sorting system according to another embodiment of the invention.

FIG. 7 illustrates a bubble valve suitable for use in the particle sorting system of the present invention.

FIG. 8 is a schematic diagram of the particle sorting system of an illustrative embodiment of the present invention.

5

FIG. 9 shows one embodiment of a particle sorting system for sorting parallel streams of particles according to the teachings of the present invention.

FIG. 10 shows one embodiment of a particle sorting system configured in a binary tree-like configuration of sorting modules according to the teachings of the present invention.

FIG. 11 illustrates another embodiment of a multi-stage particle sorting system for sorting parallel streams of particles in multiple stages.

FIG. 12 illustrates a parallel particle sorting system according to an alternate embodiment of the present invention.

FIG. 13 illustrates a parallel particle sorting system according to another embodiment of the present invention.

FIGS. 14a and 14b illustrate a particle sorting system according to another embodiment of the invention, including an optical mask to allow measurement of a particle size and/or velocity.

FIG. 15 illustrates a parallel sorting system having variable channels according to another embodiment of the present invention.

FIG. 16 illustrates a variable array design of a parallel sorting system according to another embodiment of the present invention.

FIG. 17 illustrates a parallel sorting system according to another embodiment of the present invention.

DETAILED DESCRIPTION OF THE INVENTION

The present invention provides a particle sorting system for sorting particles suspended in a liquid. The particle sorting system provides high-throughput, low error sorting of particles based on a predetermined characteristic. The present invention will be described below relative to illustrative embodiments. Those skilled in the art will appreciate that the present invention may be implemented in a number of different applications and embodiments and is not specifically limited in its application to the particular embodiments depicted herein.

The terms “duct” “channel” and “flow channel” as used herein refers to a pathway formed in or through a medium that allows for movement of fluids, such as liquids and gases. The channel in the microfluidic system preferably have cross-sectional dimensions in the range between about 1.0 μm and about 500 μm , preferably between about 25 μm and about 250 μm and most preferably between about 50 μm and about 150 μm . One of ordinary skill in the art will be able to determine an appropriate volume and length of the flow channel. The ranges are intended to include the above-recited values as upper or lower limits. The flow channel can have any selected shape or arrangement, examples of which include a linear or non-linear configuration and a U-shaped configuration.

The term “particle” refers to a discrete unit of matter, including, but not limited to cells.

The term “sensor” as used herein refers to a device for measuring a characteristic of an object, such as a particle.

The term “bubble valve” as used herein refers to a device that generates pressure pulses to control flow through a channel.

The term “carrier fluid” as used herein refers to a sheath of compatible liquid surrounding a particle for carrying one or more particles through a duct or channel.

FIG. 1 is a schematic depiction of a particle sorting system 10 according to the teachings of the present inven-

6

tion. According to one application of the present invention, the particle sorting system 10 comprises a closed channel system of capillary size for sorting particles. The channel system comprises a first supply duct 12 for introducing a stream of particles 18 and a second supply duct 14 for supplying a carrier liquid. The first supply duct 12 forms a nozzle 12a, and a stream of particles is introduced into the flow of the carrier liquid. The first supply duct 12 and the second supply duct 14 are in fluid communication with a measurement duct 16 for conveying the particles suspended in the carrier liquid. The measurement duct branches into a first branch channel 22a and a second branch channel 22b at a branch point 21. A measurement region 20 is defined in the measurement duct 16 and is associated with a detector 19 to sense a predetermined characteristic of the particles passing through the measurement region 20. Two opposed bubble valves 100a and 100b are positioned relative to the measurement duct and disposed in fluid communication therewith. The valves are spaced opposite each other, although those of ordinary skill will realize that other configurations can also be used. The bubble valves 100a and 100b communicate with the measurement duct 16 through a pair of opposed side passages 24a and 24b, respectively. Liquid is allowed to partly fill these side passages 24a and 24b to form a meniscus 25 therein. The meniscus defines an interface between the carrier liquid and another fluid, such as a gas in the reservoir of the associated bubble valve 100. An actuator 26 is also provided for actuating either bubble valve, which momentarily causes a flow disturbance in the duct to deflect the flow therein when activated by the actuator 26. As illustrated, the actuator is coupled to the bubble valve 100b. The second bubble valve 100a serves as a buffer for absorbing the pressure pulse created by the first bubble valve 100b.

The first side passage 24b is hydraulically connected to a compression chamber 70b in the first bubble valve 100b, so that if the pressure in this chamber is increased, the flow in the measurement duct near the side passage is displaced inwards, substantially perpendicular to the normal flow in the duct. The second side passage 24a, positioned opposite of the first side passage 24b is hydraulically connected to a buffer chamber 70a in the second bubble valve 100a for absorbing pressure transients. This first side passage 24b co-operates with the second side passage 24a to direct the before mentioned liquid displacement caused by pressurizing the compression chamber 70b, so that the displacement has a component perpendicular to the normal flow of the particles through the measurement duct.

Upon pressurizing the compression chamber 70b an amount of liquid is transiently discharged from the first side passage 24b. The resiliency of the second side passage 24a results upon a pressurized discharge, in a transient flow of the liquid in the duct into the second side passage 24a. The co-operation of the two side passages and the fluidic structures they interconnect causes the flow through the measurement duct 16 to be transiently moved sideways back and forth upon pressurizing and depressurizing of the compression chamber 70b induced by the external actuator 26 in response to the signal raised by the detection means 19. This transient liquid displacement, having a component perpendicular to the normal flow in the duct, can be applied in deflecting particles having predetermined characteristics to separate them from the remaining particles in the mixture.

As shown, the measurement duct 16 branches at the branch point 21 into two branches 22a, 22b and the flow rates in these branches are adjusted so that the particles normally stream through the second of the two branches 22b. The angle between the branches 22a, 22b is between 0

and 180 degrees, and preferably between 10 and 45 degrees. However, the angle can even be 0 degrees, which corresponds to two parallel ducts with a straight separation wall between them.

The particles to be sorted are preferably supplied to a measurement position in a central fluid current, which is surrounded by a particle free liquid sheath. The process of confining a particle stream is known, and often referred to as a 'sheath flow' configuration. Normally, confinement is achieved by injecting a stream of suspended particles through a narrow outlet nozzle into a particle free carrier liquid flowing in the duct **16**. By adjusting the ratio of flow rates of the suspension and carrier liquid, the radial confinement in the duct as well as the inter particle distance can be adjusted. A relatively large flow rate of the carrier liquid results in a more confined particle stream having a large distance between the particles.

In a suspension introduced by the first supply duct **12**, two types of particles can be distinguished, normal particles **18a** and particles of interest **18b**. Upon sensing the predetermined characteristic in a particle **18b** in the measurement region **20**, the detector **19** raises a signal. The external actuator **26** activates the first actuator bubble valve **100b**, when signaled by the detector **19** in response to sensing the predetermined characteristic, to create a flow disturbance in the measurement duct **16** between the side passages **24a**, **24b**. The flow disturbance deflects the particle **18b** having the predetermined characteristic so that it flows down the first branch duct **22a** rather than the second branch duct **22b**. The detector communicates with the actuator **26**, so that when the detector **19** senses a predetermined characteristic in a particle, the actuator activates the first bubble valve **100b** to cause pressure variations in the reservoir **70b** of the first bubble valve. The activation of the first bubble valves deflects the meniscus **25b** in the first bubble valve **100b** and causes a transient pressure variation in the first side passage **24b**. The second side passage **24a** and the second bubble valve **100a** absorb the transient pressure variations in the measurement duct **16** induced via the actuator **26**. Basically, the reservoir **70a** of the second bubble valve **100a** is a buffer chamber having a resilient wall or containing a compressible fluid, such as a gas. The resilient properties allow the flow of liquid from the measurement duct into the second side passage **24a**, allowing the pressure pulse to be absorbed and preventing disturbance to the flow of the non-selected particles in the stream of particles.

At the measurement region **20**, individual particles are inspected, using a suitable sensor **19**, for a particular characteristic, such as size, form, fluorescent intensity, as well as other characteristics obvious to one of ordinary skill. Examples of applicable sensor, known in the art, are various types of optical detection systems such as microscopes, machine vision systems and electronic means for measuring electronic properties of the particles. Particularly well known systems in the field are systems for measuring the fluorescent intensity of particles. These systems comprise a light source having a suitable wavelength for inducing fluorescence and a detection system for measuring the intensity of the induced fluorescent light. This approach is often used in combination with particles that are labelled with a fluorescent marker, i.e. an attached molecule that upon illuminating with light of a particular first wavelength produces light at another particular second wavelength (fluorescence). If this second wavelength light is detected, the characteristic is sensed and a signal is raised.

Other examples include the measurement of light scattered by particles flowing through the measurement region.

Interpreting the scattering yield information on the size and form of particles, which can be adopted to raise a signal when a predetermined characteristic is detected.

The actuator **26** for pressurizing the compression chamber of the first bubble valve can comprise an external actuator that responds to a signal from the sensor that a particle has a selected predetermined characteristic. There are two classes of external actuators that are suitable for increasing the pressure. The first class directly provides a gas pressure to the liquid in the first side passage **24b**. For example, the actuator may comprise a source of pressurized gas connected with a switching valve to the liquid column in the side passage **24b**. Activation of the switch connects the passage to the source of pressurized gas, which deflects the meniscus in the liquid. Upon deactivation, the switch connects the passage **24b** back to the normal operating pressure.

Alternatively, a displacement actuator may be used in combination with a closed compression chamber having a movable wall. When the displacement actuator displaces the wall of the compression chamber inward, the pressure inside increases. If the movable wall is displaced back to the original position, the pressure is reduced back to the normal operating pressure. An example of a suitable displacement actuator is an electromagnetic actuator, which causes displacement of a plunger upon energizing a coil. Another example is the use of piezoelectric material, for example in the form of a cylinder or a stack of disks, which upon the application of a voltage produces a linear displacement. Both types of actuators engage the movable wall of the compression chamber **70** to cause pressure variations therein.

FIGS. **2** through **4** illustrate the switching operation of switch **40** in the particle sorting system **10** of FIG. **1**. In FIG. **2**, the detector **19** senses the predetermined characteristic in a particle and generates a signal to activate the actuator **26**. Upon activation of the actuator, the pressure within the reservoir **70b** of the first bubble valve **100b** is increased, deflecting the meniscus **25b** and causing a transient discharge of liquid from the first side passage **24b**, as indicated by the arrow. The sudden pressure increase caused at this point in the duct causes liquid to flow into the second side passage **24a**, because of the resilient properties of the reservoir of the second bubble valve **100a**. This movement of liquid into the second side passage **24a** is indicated with an arrow. As a result, as can be seen in the figure, the flow through the measurement duct **16** is deflected, causing the selected particle of interest **18b** located between the first side passage **24b** and the second side passage **24a** to be shifted perpendicular to its flow direction in the normal state. The flow resistances to the measurement duct **16**, the first branch **22a** and the second branch **22b** is chosen so that the preferred direction of the flow to and from the first side passage **24b** and the second side passage **24a** has an appreciable component perpendicular to the normal flow through the measurement duct **16**. This goal can for instance be reached by the first branch **22a** and the second branch **22b** so that their resistances to flow is large in comparison with the flow resistances of the first side passage **24b** and the second side passage **24a**.

FIG. **3** shows the particle sorting system **10** during the relief of the first bubble valve reservoir when the particle of interest **18b** has left the volume between the first side passage **24b** and the second side passage **24a**. The actuator **26** is deactivated, causing the pressure inside the reservoirs **70a**, **70b** to return to the normal pressure. During this relief phase there is a negative pressure difference between the two reservoirs **70a**, **70b** of the bubble valves, causing a liquid

flow through the first side passage **24b** and the second side passage **24a** opposite to the liquid flow shown in the previous figure and as indicated by the arrows.

FIG. 4 illustrates the particle sorting system **10** after completion of the switching sequence. The pressures inside the reservoirs of the bubble valves are equalized, allowing the flow through the measurement duct **16** to normalize. As the particle of interest **18b** has been displaced radially, it will flow into the first branch **22a**, while the other particle continue to flow into the second branch **22b**, thereby separating the particles based on the predetermined characteristic.

This process of detecting and selective deflecting of particles may be repeated many times per second for sorting particles at a high rate. Adopting the fluid switching as described, switching operations may be executed up to around several thousand switching operations per second, yielding sorting rates in the order of million sorted particles per hour.

According to another embodiment of the invention, the actuator bubble valve **100b** and the buffer bubble valve **100a** may be placed in different positions. For example, as shown in FIG. 5, the actuator bubble valve **100b** and the first side passage **24b** and/or the buffer bubble valve **100a** and the second side passage **24a** may be placed upstream from the branch point **21**. The components may be placed in any suitable location, such that the flow resistance between the actuator chamber **70b** and the buffer chamber **70a** is less than the flow resistance between any of these latter components and other pressure sources. More particularly, the actuator chamber **70b** and the buffer chamber **70a** may be placed such that the flow resistance between them is less than the flow resistance between a selected particle and a subsequent particle in the stream of particles. The positioning of the components in this manner thus prevents a pressure wave generated by the above-described method of deflecting a single selected particle, from travelling upstream or downstream and affecting the flow of the remaining particles in the stream of particles. A larger difference in flow resistances results in a higher level of isolation of the fluidic switching operation with associated pressure transients from the flow characteristics in the rest of the system. Moreover, the in-situ dampening of generated pressure pulses applied for sorting allows the implementation of sorting networks comprising a plurality of switches **40**, each of which is hydraulically and pneumatically isolated from the others.

According to another embodiment, shown in FIG. 6, the particle sorting system of the present invention may use any suitable pressure wave generator (in place of a bubble valve) in combination one or more bubble valves serving as a buffer, such as valve **100b**. For example, the pressure wave generator **260** may comprise an actuator such as a piezoelectric column or a stepper motor, provided with a plunger that can act upon the flowing liquid, either directly or via deflection of the channel system, to selectively deflect particles when the actuator is activated by a signal. Other suitable pressure wave generators include electromagnetic actuators, thermopneumatic actuators and a heat pulse generator for generating vapor bubbles in the flowing liquid by applying heat pulses. The buffer bubble valve **100b** is positioned to absorb the pressure wave created by the pressure wave generator **260** to prevent flow disturbance in the other particles of the particle stream. The spring constant of the buffer **100b** may be varied according to the particular requirements by varying the volume of the buffer chamber **70b**, the cross-sectional area of the side passage **24b** and/or

the stiffness or the thickness of a flexible membrane (reference **72** in FIG. 7) forming the buffer chamber **70b**.

FIG. 7 illustrates an embodiment of a valve **100** suitable for creating a pressure pulse to separate particles of interest from other particles in a stream of particles and/or acting as a buffer for absorbing a pressure pulse according to the teachings of the present invention. As shown, the valve **100** is formed adjacent to a side passage **24a** or **24b** formed in a substrate which leads to the measurement duct **16**. The side passage **24a** includes a fluid interface port **17** formed by an aperture in the side wall of the passage. A sealed compression chamber **70** is positioned adjacent to the side passage **24a** and communicates with the side passage through the fluid interface port. The illustrative chamber **70** is formed by a seal **71** and a flexible membrane **72**. The carrier fluid in the side passage **24a** forms a meniscus **25** at the interface between the side passage and the chamber. The actuator **26** depresses the flexible membrane to increase the pressure in the chamber, which deflects the meniscus and causes a pressure pulse in the carrier fluid.

FIG. 8 shows a sorting module **50** having an appropriate supply duct **52** for providing a stream of particles to be sorted as well as a first outlet duct **54** and a second outlet duct **56**, either of which can carry the particles sorted in the sorting module **50**. The sorting module **50** comprises a detector system **19** for sensing particles entering the sorting module **50** via the supply duct **52** can be operationally connected to a switch **40** for providing the required switching capabilities to sort particles. The first branch **22b** and the second branch **22a**, FIG. 1, can be disposed in fluidic connection with the outlet duct **54** and the second outlet duct **56**.

FIG. 9 shows a particle sorting system **500** according to an alternate embodiment of the invention, comprising a plurality of sorting modules **50** that can be coupled together in any appropriate configuration. For example, the modules **50** in this embodiment are coupled in parallel. The outlet ducts **54** of the sorting modules **50** are coupled to a first combined outlet **58**, the second outlet ducts **56** are coupled to a second combined outlet **60**. The parallel arrangement of sorting modules yields a system of combined sorting module **50** having an overall sorting rate of N times the sorting rate of an individual sorting module **50**, where N is the number of parallel connected sorting module **50**.

FIG. 10 shows a particle sorting system **550** according to another embodiment, comprising a first sorting module **50a** in series with a second sorting module **50b**. The second sorting module **50b** may be equipped for sorting particles having a predetermined characteristic the same or different than the predetermined characteristic of the particles sorted by the first sorting module **50a**. The particle stream enters the first sorting module **50a** through the supply duct **52** and may contain at least two types of particles. A first type of particle is sorted in the first sorting module **50a** and exits through the first outlet duct **54a**. The remaining particles exit the first sorting module **50a** through second outlet duct **56a** and are introduced into the second sorting module **50b** via the second supply duct **52b**. From this stream of particles, particles having the other predetermined characteristic are sorted and exit through the second outlet duct **54b**. Particles that possess neither of the two predetermined characteristics exit the second sorting module **50b** via the second outlet duct **56b**. Those of ordinary skill will readily recognize that any suitable type of sorting module **50** can be used, and can be coupled together in a variety of ways, depending upon the desired results.

FIG. 11 shows a hierarchical architecture for high throughput-low error sorting according to another embodiment of the present invention. The illustrated embodiment is a two-stage particle sorting system **800** for sorting a plurality of parallel particles streams in a first stage, aggregating the outputs of the first stage and then performing a secondary sorting process on the output of the first stage. An input stream of particles in suspension **80** from a particle input chamber **88** is split among N single sorting channels **81a-81n**, each channel being capable of sorting a selected number of particles per second. Each channel **81** includes a detection region **84** for examining the particles and identifying particles that have a predetermined characteristic, and a switching region **82** for separating the particles having the predetermined characteristic from the other particles in the stream, as described above. The switching region **82** produces two output streams of particles: a "selected" stream and a "rejected" stream in its switching region **82** based on the measured particle characteristics at the detection region **84**. The "selected" streams from each channel are aggregated in an aggregation region **86** into one stream to be sorted again in a secondary sorting channel **810**. As shown, the secondary sorting channel **810** repeats the sorting process of detecting and sorting based on a predetermined characteristic.

Given that each single channel sorting process produces some error (y) rate (y is a probability less than one of a particle being "selected" by mistake) of mistaken selections, the hierarchical architecture produces an lower error rate of y^2 for a 2-stage hierarchy as drawn or y^n for an n-stage hierarchy. For example, if the single channel error rate is 1% the 2-stage error rate is 0.01% or one part in 10^4 .

Alternatively, the architecture could have M primary sets of N sorting channels per secondary channel. Given that the application wants to capture particles that have a presence in the input at rate z and single channel sorters have a maximum sorting rate x particles per second. The system throughput is $M*N*x$ in particles per second. The number of particles aggregated in N channels per second is $N*x*z$ and so $N*z$ must be less than 1 so that all particles aggregated from N channels can be sorted by a single secondary channel. To increase throughput above $N=1/z$ one must add parallel groups of N primary+1 secondary channels. Overall throughput then comes from $M*N*x$ with M secondary channels.

FIG. 12 show a parallel-serial particle sorting system **160** according to another embodiment of the invention. The parallel-serial particle sorting system **160** includes a first parallel sorting module **161** and a second parallel sorting module **162**. The first sorting module **161** is applied in multiple marked particles and particles having both markers are sorted out and conveyed through the exit channel **165**.

FIG. 13 shows another parallel-serial particle sorting system **170**. The first parallel sorting module **171** separates particles having a first marker, collects the particles from the different channels and conveys the particles having the first marker through the first exit channel **175**. All other particles are then fed into a second parallel sorter **172** for sorting particles having a second marker. The particles having the second marker are collected and conveyed through a second exit channel **176**. Particles having neither the first marker nor the second marker are conveyed through a third exit channel **177**.

According to one embodiment of the invention, shown in FIGS. **14a** and **14b**, the particle sorting system may include sensors for measuring velocity, location and/or size of particles. The measurement of velocity, location and/or size

may be made simultaneously with classification of the particles for sorting or at a different time. In parallel channel based systems, as shown in FIG. 11, the different channels may have different flow resistances, causing the velocity of the particles or cells in each channel to be different. In systems where the detection region **84** is separated from the switching region **82** by a distance L, the velocity of the particles in the channel **81** must be known in order to set the switching time delay T (i.e., the time to delay switch actuation relative to the moment of detection of a target particle).

In most optical systems for detecting cells or particles, the region in which the cell creates light on the photo detector in the detection region will have a much greater size than the size of a cell diameter. Therefore, when light is detected in the detection region, the cell may be anywhere in the region, making it difficult to pinpoint the exact location of the cell. To provide more accurate detection, many pixels of an optical detector could be packed across the detection region, but this would have a large cost and require complex support electronics.

According to an illustrative embodiment of the invention, an optical mask **140** may be added to the detection region to provide accurate velocity detection by depositing a "masking pattern" directly on the sorting chip. The masking patterns can be deposited so that an edge in the masking pattern is precisely located (to <1 um precision with current technology) relative to the cell sorting actuator region **82**. A single optical detector catching light from the cell in the detection region **84** will see light when the cell is not masked. The duration of the light being turned off by one of the connected opaque parts "bars" of the mask of known length gives a measurement of velocity.

A mask pattern that has several bars **141** of size ranging from 10 um to 30 um in 1 um steps results in only bars of size larger than the cell minimizing the signal from the cell. Therefore, such a pattern can also be used to measure the size of the cell independently of its signal. Such a "gradient mask" also produces a pattern in the optical detector that can be analyzed to measure velocity several times for reducing the variance in the velocity estimate. The pattern in the light induced by the mask **140** also allows the detector to identify each edge in the mask **140**. If the bars **141** were all the same, the light signal for each bar would be the same, and one could only tell them apart by sequence. Therefore, a gradient mask pattern will allow a single detector looking at a broad region (several times the size of a cell) to measure the velocity of the cell, measure the exact position inside the detection region **84** with about 1 um precision relative to the channel structures and the actuator location on chip and identify the size of the cell to precision given by the gradient pattern. The gradient mask **140** allows the detector to measure these parameters independent of the magnification of the optical system or the nature of the optical detector itself.

One skilled in the art will recognize that other devices for measuring the size, position and or velocity of a particle in the sorting system in accordance with the teachings of the invention. Suitable devices are readily available and known to those of ordinary skill in the art.

According to another embodiment, shown in FIG. 15, the particle sorting system comprises an array **8000** of non-identical sorting channels. The use of a parallel array comprising a series of non-identical sorter channels **810a-810n** is more efficient in terms of space, use of optical power and adaptation to optimal external actuators. Since the velocity of particles can be accurately sensed using a sensor as

described above, the channels do not require a fixed delay between the detection of a property and actuation of a switch to deflect a particle having the detected property. Therefore, certain parameters of the channel, such as the distance L between a detector **84** and a switch **82** or the shape of the path between the detector **84** and the switch **82** can be varied.

Using a single laser for each wavelength optical illumination directed perpendicular to the chip, the laser is required to illuminate an area defined by: (number of channels) \times ((channel width at detection region)+(inter channel spacing C)) (See FIG. **15**). However, the active area where light can be absorbed to create fluorescence is only the area of the channels: (number of channels) \times (channel width), which leaves a fill factor of: (channel width)/(channel width+C). The fill factor is preferably close to 100% to avoid wasting available input light.

Therefore, minimizing the interchannel spacing in a parallel sorting system is important to the optical detection region and optical system efficiency. In the variable array design of the present invention, shown in FIG. **16**, the spacing of the channels in the detection region **84** approaches the width of the channels, so that light utilization approaches about 50%. The channel spacing in the actuation region **82** may be larger, as shown in FIG. **16**. The location of actuators **26** along the channel may also be varied to make a larger available radius for external driver actuators.

The variable array **8000** may also include meanders in selected channels for balancing flow resistances of all the channels so that given a constant pressure drop across all the channels the velocities of particles are nearly matched. These can be added either upstream or downstream of the illustrated system, i.e., on in the region between the detectors and actuators. As the lengths L_i between each channel's detection region **821** and its actuator **26i** is known from the design, the measurement of the particle velocity at the same time as the determination regarding which particles to keep provides an improved cell sorting system.

FIG. **17** illustrates a particle sorting system **1700** according to yet another embodiment of the invention. The particle sorting system **1700** includes a plurality of sorting modules **1701** operating in parallel. The system **1700** includes an input region **1710** for introducing samples to each sorting module and a detection region **1720** for measuring a predetermined characteristic of particles each sorting channel **1702** in the detection region. The system also includes a switch region **1730**, including an actuator in each sorting module for separating particles having a predetermined characteristic from particles that do not have the predetermined characteristic. As shown, in the embodiment of FIG. **17**, the sorting channels **1702** distance between each sorting channel in the detection region **1720** is less than the inter-channel distance in the switch region **1730**. The close spacing in the detection region enables cost saving when a laser is used to detect the particles, while the more distant separation in the switch region **1730** accommodates various sized actuators.

The particle sorting system **1700** may also include a secondary sorting module **1740** for repeating the sorting process of detecting and sorting based on a predetermined characteristic to increase the accuracy of the sorting process. According to one embodiment, the system may include an enrichment region **1750** between the array of primary sorting modules **1701** and the secondary sorting module **1740** for transitioning the particles from the primary sorting process to the secondary sorting process. According to an illustrative embodiment, the enrichment region **1750** tran-

sitions the particles by removing excess carrier fluid from the particles before passing the particles to the secondary sorting module **1740**. The enrichment region **1750** may also include a hydration device for adding secondary sheet fluid to the particles after enrichment. The enrichment region **1750** may comprise a membrane inserted into outlet channel **1703**, an enrichment channel intersecting the outlet channel **1703** and a membrane separating the outlet channel from the enrichment channel. Excess carrier fluid is removed from the stream of selected particles in the outlet channel **1703** through the membrane and into the enrichment channel before passing the selected particles into the secondary sorting module **1740**.

A suitable system for forming the enrichment region is described in U.S. Ser. No. 10/329,018, filed on Dec. 23, 2002, the contents of which are herein incorporated by reference.

According to the illustrative embodiment, the removed carrier fluid may be recycled and fed back into the inlet of the primary channels. A recycling channel or other device may connect the enrichment region to the primary channel to allow re-use of the carrier fluid for subsequent sorting process. Alternatively, the carrier fluid may be removed from rejected particles and introduced into the primary channel inlets prior to discarding the rejected particles.

The present invention has been described relative to an illustrative embodiment. Since certain changes may be made in the above constructions without departing from the scope of the invention, it is intended that all matter contained in the above description or shown in the accompanying drawings be interpreted as illustrative and not in a limiting sense.

It is also to be understood that the following claims are to cover all generic and specific features of the invention described herein, and all statements of the scope of the invention which, as a matter of language, might be said to fall therebetween.

Having described the invention, what is claimed as new and protected by Letters Patent is:

1. A particle sorting chip comprising:
 - a duct configured to convey particles in a stream, the duct including an inlet and a plurality of flow-through outlet channels formed in a substrate;
 - a first chamber formed in the substrate, the first chamber in fluid communication with the duct via a first side opening and otherwise sealed, the first side opening positioned upstream of the plurality of flow-through outlet channels; and
 - an actuator provided on the substrate and associated with the first chamber, the actuator configured to increase a pressure within the first chamber and to discharge an amount of fluid from the first side opening into the duct during a switching operation.
2. The particle sorting chip of claim 1, wherein the actuator is a piezoelectric actuator bonded to the chip.
3. The particle sorting chip of claim 1, wherein the actuator is a heat pulse generation actuator configured to generate a vapor bubble within the actuator chamber.
4. The particle sorting chip of claim 1, wherein the first chamber has a flexible wall and wherein movement of the flexible wall causes the first chamber to transiently discharge an amount of fluid through the first side opening into the duct.
5. The particle sorting chip of claim 1, further comprising a second chamber in fluid communication with the duct via a second side opening, wherein the first side opening and the

15

second side opening are positioned on opposite sides of the duct upstream of the plurality of flow-through outlet channels.

6. The particle sorting chip of claim 5, wherein the second chamber is otherwise sealed.

7. The particle sorting chip of claim 1, further comprising a gradient mask associated with the duct, the gradient mask configured to produce a pattern in an optical detector.

8. The particle sorting chip of claim 1, further comprising an optically detectable pattern in a detection region of the duct, the optically detectable pattern configured for simultaneously transmitting signals to determine a time delay and a classification of the selected particle.

9. The particle sorting chip of claim 1, further comprising an optical mask having an optical pattern extending along a length of the duct, the optical mask configured to provide information on the velocity of the selected particle.

10. The particle sorting chip of claim 1, further comprising a plurality of ducts, each duct configured to convey particles in a stream, each duct including an inlet and a plurality of flow-through outlet channels, wherein the par-

16

ticles normally flow from the inlet into a first outlet channel of the plurality of flow-through outlet channels, and each duct including a first chamber configured to selectively discharge a transient pressure pulse during a switching operation via a first side opening of the duct to a selected particle having a predetermined characteristic.

11. The particle sorting system of claim 1, further comprising a sensor configured to detect a measurement of velocity of the selected particle.

12. The particle sorting system of claim 1, further comprising an optically detectable pattern for spatially modulating signals from a detection region of the duct, the optically detectable pattern configured for simultaneously transmitting signals to determine a time delay and a classification of the selected particle.

13. The particle sorting system of claim 1, further comprising an optical mask having an optical pattern associated with a length of the duct, the optical mask configured to provide information on the velocity of the selected particle.

* * * * *